

Mission Success

Ensign-Bickford Aerospace & Defense Company (EBAD) is dedicated to supporting our customers in the aerospace and defense industry through on-time delivery of innovative products that exceed expectations and assure mission success.



TiNi™ Ejector Release Mechanisms

Our TiNi™ Ejector Release Mechanisms are utilized in satellite applications to provide a simple and effective non-pyro field resettable separation system with allowances for up to 5° angular misalignment during deployment. Ranging in size from 250 lbf to 4,000 lbf of Max release load, the ejectors offer a versatile solution from satellite solar array deployments, satellite dispensing, off angle optical cover, and antenna releases.

Principle of Operation

The ejector is a reliable fast operating device that utilizes a Shape Memory Alloy (SMA) wire to release a latch to allow for the internal compression springs to retract an internal pin and allow for the external ball locks to disengage and release the coupler.

In the fully reset mode, the internal circuit is closed. When sufficient power is applied, the current raises the temperature of the SMA wire and subsequently contracts at its transition temperature. This allows internal ball locks to release and internal drive springs to retract a pin into the body of the device.

Once the pin drops, external ball locks are disengaged allowing the external springs to “kick off” the coupler. A spherical seat is incorporated to allow for up to 5° angular misalignment during dispensing. After actuation, the circuit is open allowing no power to continue to heat the SMA wire and provides the user with positive feedback that the device has actuated.

The device is reset with a custom tool that aligns the coupler back onto the post and pulls the internal pins to reengage the external ball locks.

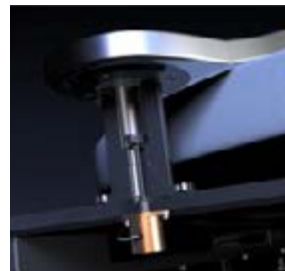

Before dispensing



After dispensing

Applications

Qualified in 2001, EBAD's TiNi™ ejectors have extensive heritage in space applications. Such applications include solar array and instrument deployment, satellite dispensing, hinged cover release, and other space applications where an off angle deployment is desired.

Key Features

- Non-pyrotechnic
- Easy to field reset and simple to use
- Minimum 50 cycles
- Redundant firing circuit
- Maximum reliability through design simplicity
- Flight pedigree and testability

Alternative applications include parachute releases, underwater acutations, and modifications into other mechanisms such as gas cylinder penetrators.

Construction

As a derivative of the EBAD TiNi™ Pin Pullers, our Ejector Release Mechanisms utilize a Shape Memory Alloy (SMA) wire, in which the wire is threaded through a latch and attached to the electrical contacts. The latch retains an internal ball bearings that keeps the compressed drive springs in place before actuation. Another smaller internal reset spring is installed to assist in the reset process.

Additional ball locks are incorporated between the output pin and the coupler. The kick off spring assists in keeping the external ball locks in place after actuation.

The ejector is fully vented and typically the enclosure is made with aluminum alloy. The coupler is custom 455 SS with a ticon finish.

Alternative voltages utilize an internal resistor to protect the SMA wire from overheating.

TiNi® ERM Ejector Release Mechanisms Family Technical Specifications

Ejector Family	E250	E500	E1000	E2000	E4000
Max Release Load	250 lbf (1,112 N)	500 lbf (2,224 N)	1,000 lbf (4,448 N)	2,000 lbf (8,900 N)	4,000 lbf (17,800 N)
Proof Load	350 lbf (1,557 N)	700 lbf (3,114 N)	1,400 lbf (6,230 N)	2,500 lbf (11,125 N)	5,000 lbf (22,400 N)
Max Torque	92 in-oz	14 in-lb	32 in-lb	70 in-lb	250 in-lb
Coupler Kick Off-Force	1.5 lbf	6.5 lbf	9.5 lbf	8.5 lbf	18 lbf
Max Misalignment Capability	+/- 5° engagement and deployment				
Mass	2.7 oz (75 g)	3.6 oz (100 g)	5.6 oz (160 g)	10.6 oz (300 g)	18.7 oz (530 g)
Operating Current	.75 to 2.5 A	1.25 to 4 A		2.25 A to 6.5 A	
Resistance	3.3±.3 Ω	2.2±.3 Ω	1.6±.3 Ω	2.2±.3 Ω	2.5±.3 Ω
Function Time @ 23°C	100 ms max @ 1.25 A	100 ms max @ 2.5 A		100 ms max @ 4A	
Cycle Life (min)	50				
Operating Temp	-65°C + 70°C				
Height (without coupler) ^x	1.375 in	1.625 in	2.00 in	2.65 in	3.3 in
Height (with coupler) ^y	2.195 in	2.475 in	2.95 in	3.93 in	4.8 in
Max Diameter (with flange) ^z	1.85 in	2.1 in	2.35 in	3.00 in	3.825 in
Std Coupler Engagement Size	.138 in-32	.164 in-32	.190 in-32	.250 in-28	.375 in-24

Contact EBAD about alternative voltages/resistance, mounting flanges, and coupler types

TiNi™ Ejector Release Mechanism Mechanical Interface Drawing (for reference)

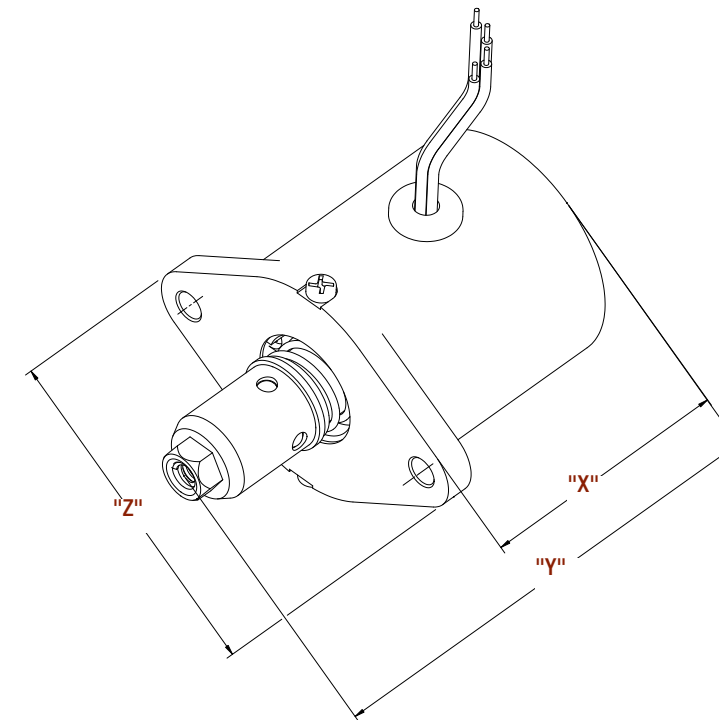

TiNi™ Ejector Release Mechanisms (ERM) Family of products

ENSIGN-BICKFORD AEROSPACE & DEFENSE COMPANY
640 HOPMEADOW STREET, P.O. BOX 429, SIMSBURY, CT 06070, USA www.EBAD.com

Attention: The information and recommendations described in this brochure cannot possibly cover every application of the products or variation of conditions under which the products are used. The recommendations here in are based on the manufacturer's experience, research and testing. They are believed to be accurate, but no warranties are made, express or implied. In addition, the specifications contained herein are all nominal which represent our current production. The products described may be subject to change. Please feel free to contact Ensign-Bickford Aerospace & Defense Company for verification. No Warranties or Liabilities: THE PRODUCTS DESCRIBED HEREIN are sold "AS IS" and without any warranty or guaranty, express, or implied, arising by law or otherwise including without limitation any warranty of merchantability or fitness for a particular purpose. Buyer and user agree further to release and discharge seller from any and all liabilities whatsoever arising out of the purchase or use of any product described herein whether or not such liability is occasioned by seller's negligence or based upon strict products liability or upon principles of indemnity or contribution. Content©2021 Ensign-Bickford Aerospace & Defense Company, Simsbury, CT 06070, U.S.A.